

CONSTRUCTION	ROTATION	DISCHARGE PORT
HORIZONTAL-LEFT	CLOCKWISE [CW]	TOP
	COUNTER-CLOCKWISE [CCW]	BOTTOM

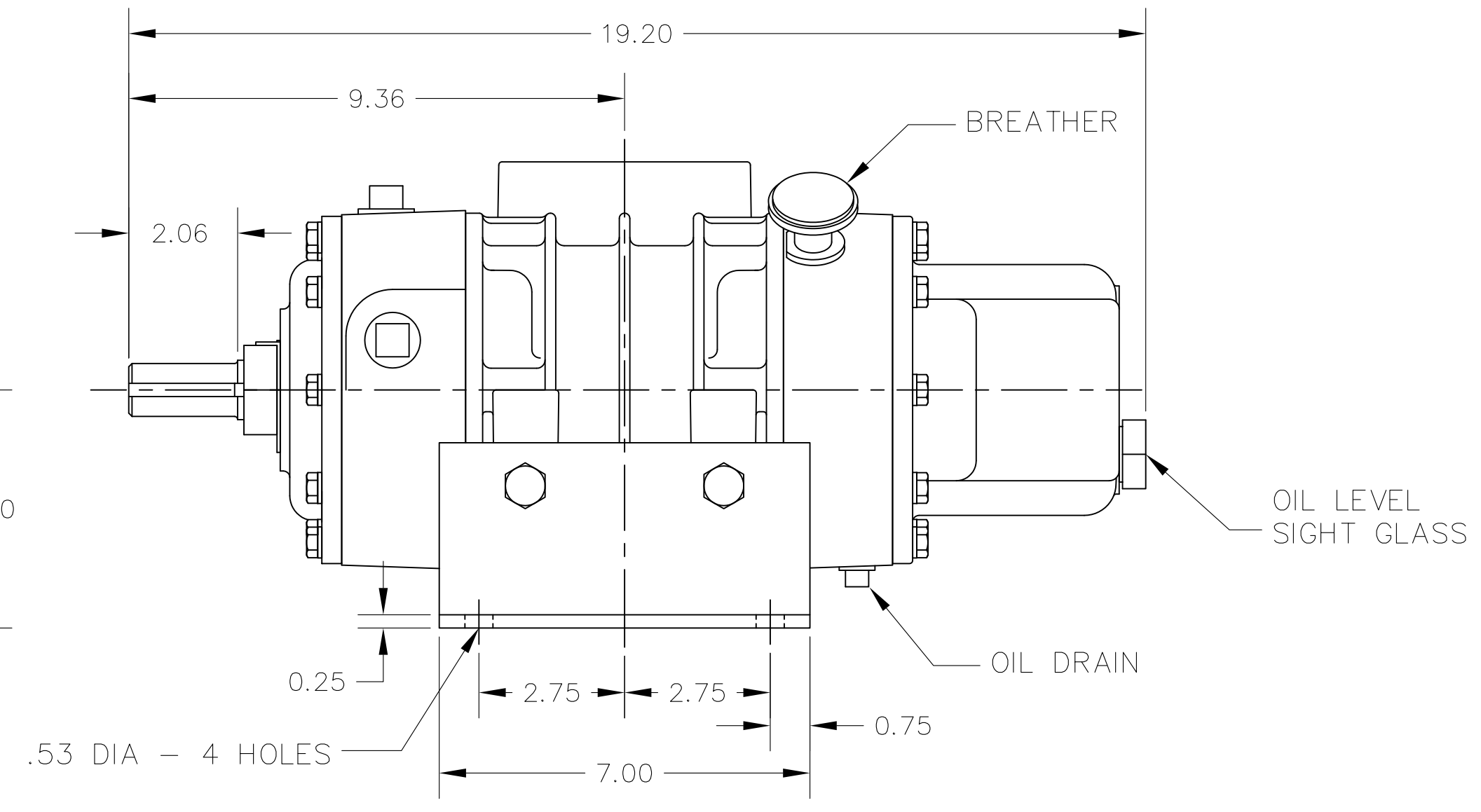
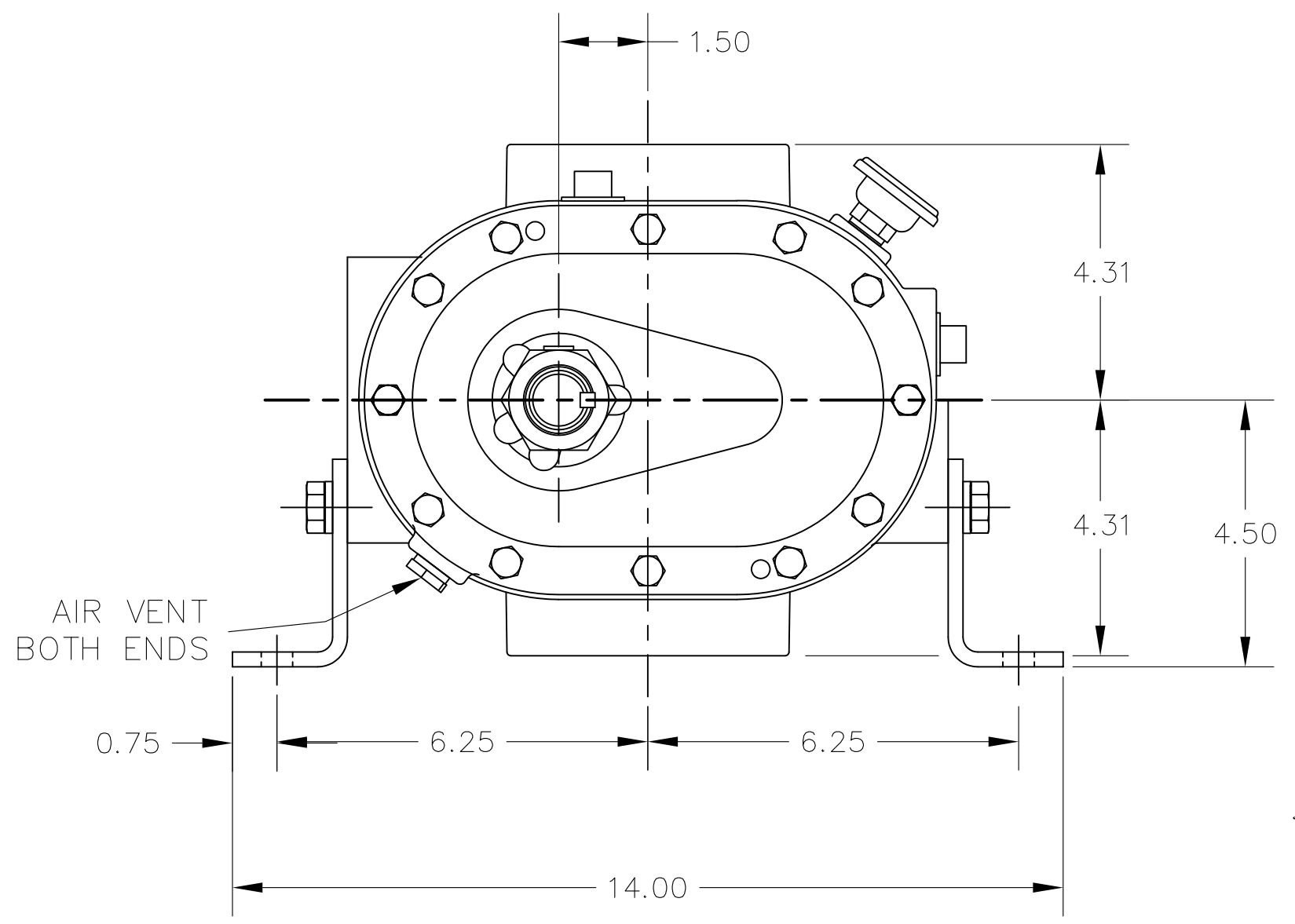
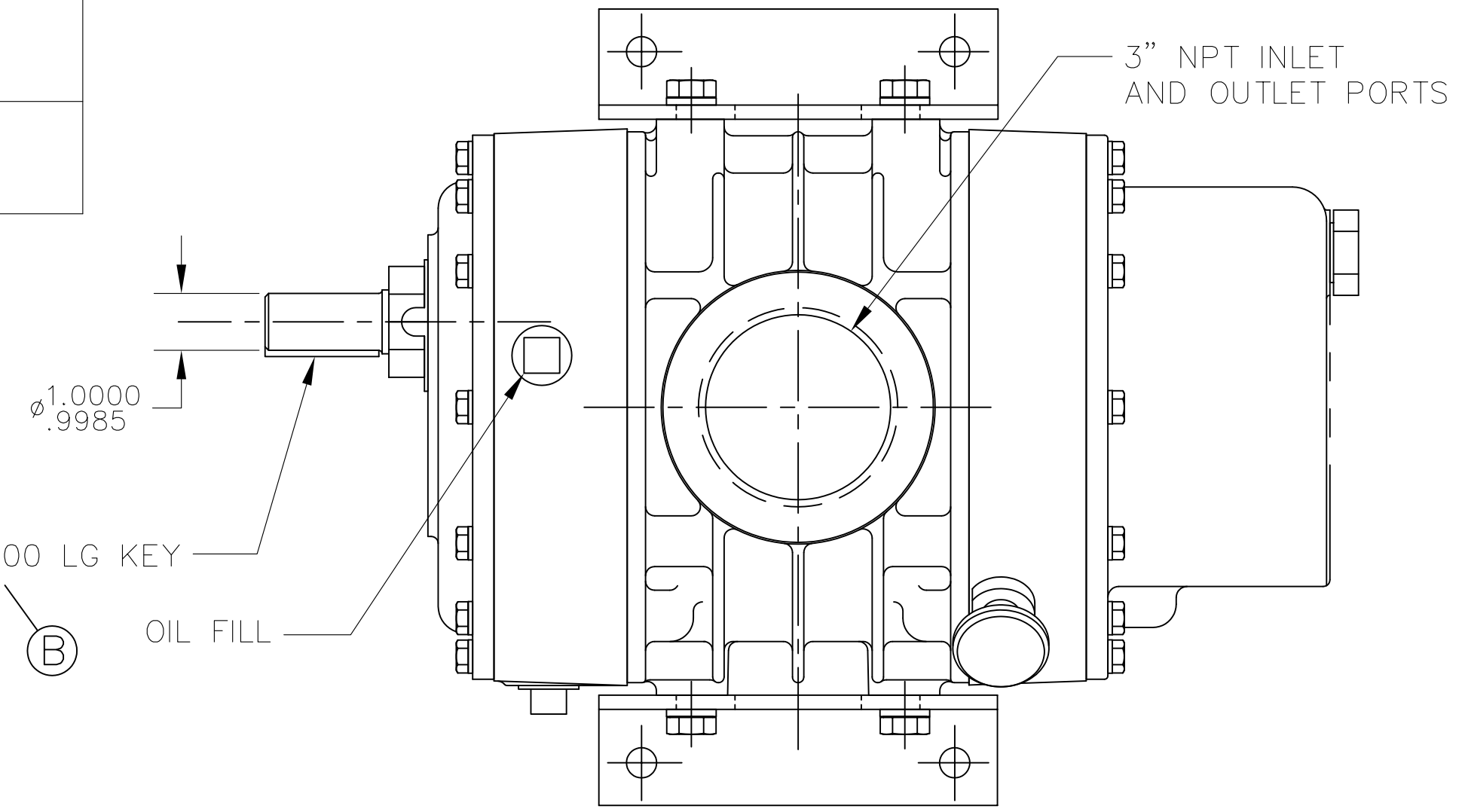

ESTIMATED WEIGHT - 135 LBS

NOTE: DIMENSIONS ARE +/- .06 INCHES UNLESS OTHERWISE SPECIFIED

DIMENSIONS AND TOLERANCING PER ASME Y14.5M-1994

CONFIDENTIAL - THE INFORMATION CONTAINED IN THIS DOCUMENT IS THE PROPERTY OF GARDNER DENVER MACHINERY INC. IT IS NOT FOR PUBLIC DISCLOSURE. POSSESSION OF THE INFORMATION DOES NOT CONVEY ANY RIGHT TO LOAN, SELL OR DISCLOSE THE INFORMATION. UNAUTHORIZED REPRODUCTION OR USE OF THE INFORMATION IS PROHIBITED. THIS DOCUMENT IS TO BE RETURNED TO GARDNER DENVER MACHINERY INC. UPON COMPLETION OF THE PURPOSE FOR WHICH IT IS LOANED OR UPON REQUEST.

TAP DRILL DEPTHS ARE MAXIMUM. FULL THD. DEPTHS ARE MINIMUM.

FINISH OF CHAMFERS & FILLETS TO CONFORM TO ROUGHEST ADJACENT AREA

SURFACE ROUGHNESS MAX. PER ASA SPEC.

LET.	REVISION	DATE	DR.	CK.	LET.	REVISION	DATE	DR.	CK.	LET.	REVISION	DATE	DR.	CK.
A	RELEASED (C/M 1018300)													
B	WAS 1.75LG: ECN 1027922	10/21/05	TWT	RS										

Gardner Denver
 Gardner Denver Inc.
 Peachtree City, Georgia

TOLERANCES: UNLESS OTHERWISE SPECIFIED
 DECIMAL .XX ± .02 .XXX ± .010
 NON-DECIMAL ± 1/16 ANGLES ± 1°

HEAT TREAT SPEC. -

SHEET 1 OF 1

FOR ALL CURRENT SPECIFICATIONS REFER TO BILL OF MATERIAL			
NAME: OUTLINE-BARE UNIT MODEL 3006 HL			
DR.	SLM	10/14/03	MET. APP.
CK.	SM	10/14/03	ENG. APP.
SCALE	3/8		
303GGB800			
FILE NO.	C	CAD/CAM	