

CONSTRUCTION	ROTATION	DISCH PORT
VERTICAL BOTTOM	CLOCKWISE (CW)	LEFT SIDE
	COUNTERCLOCKWISE (CCW)	RIGHT SIDE
VERTICAL TOP	CLOCKWISE (CW)	RIGHT SIDE
	COUNTERCLOCKWISE (CCW)	LEFT SIDE

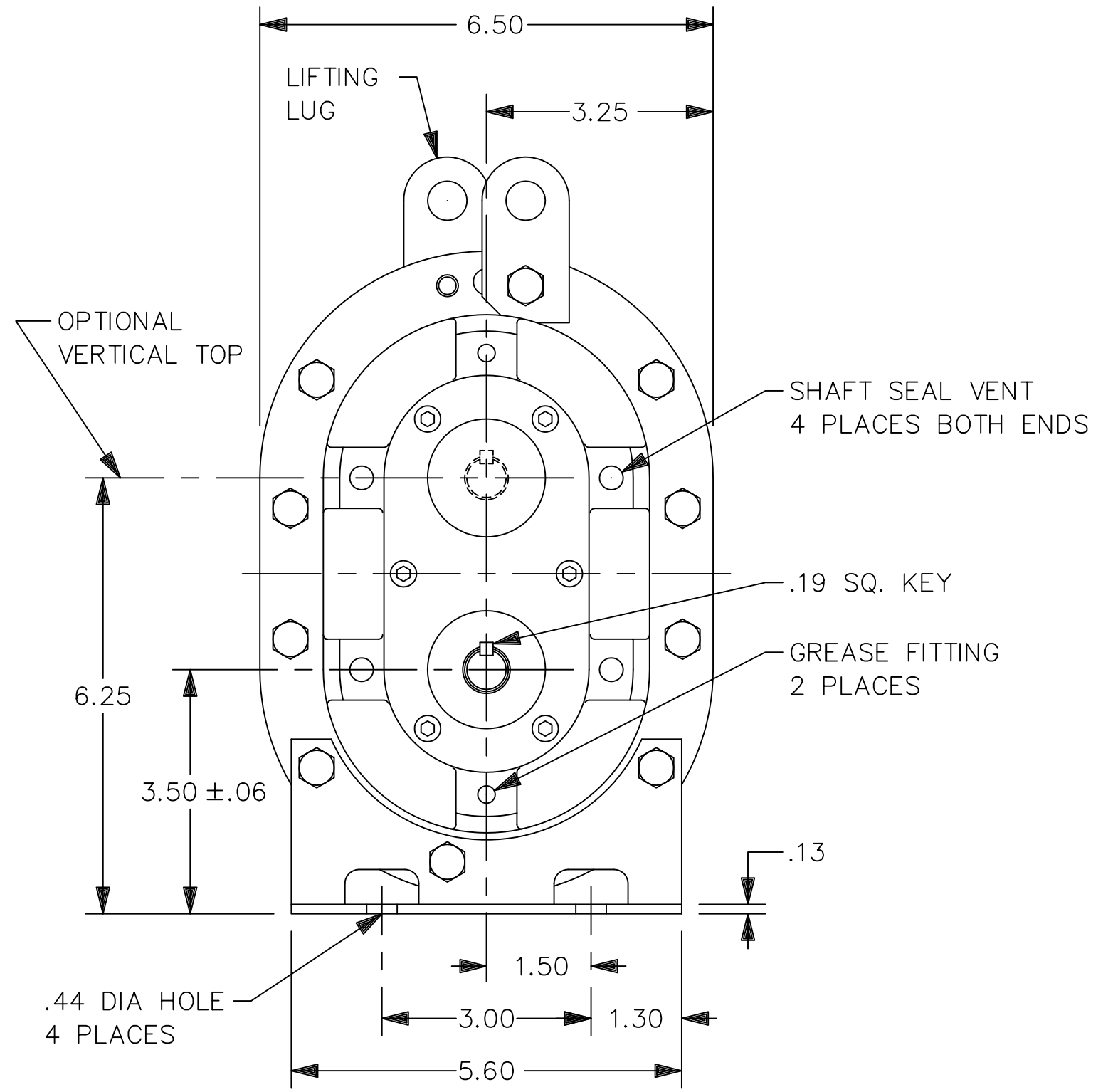
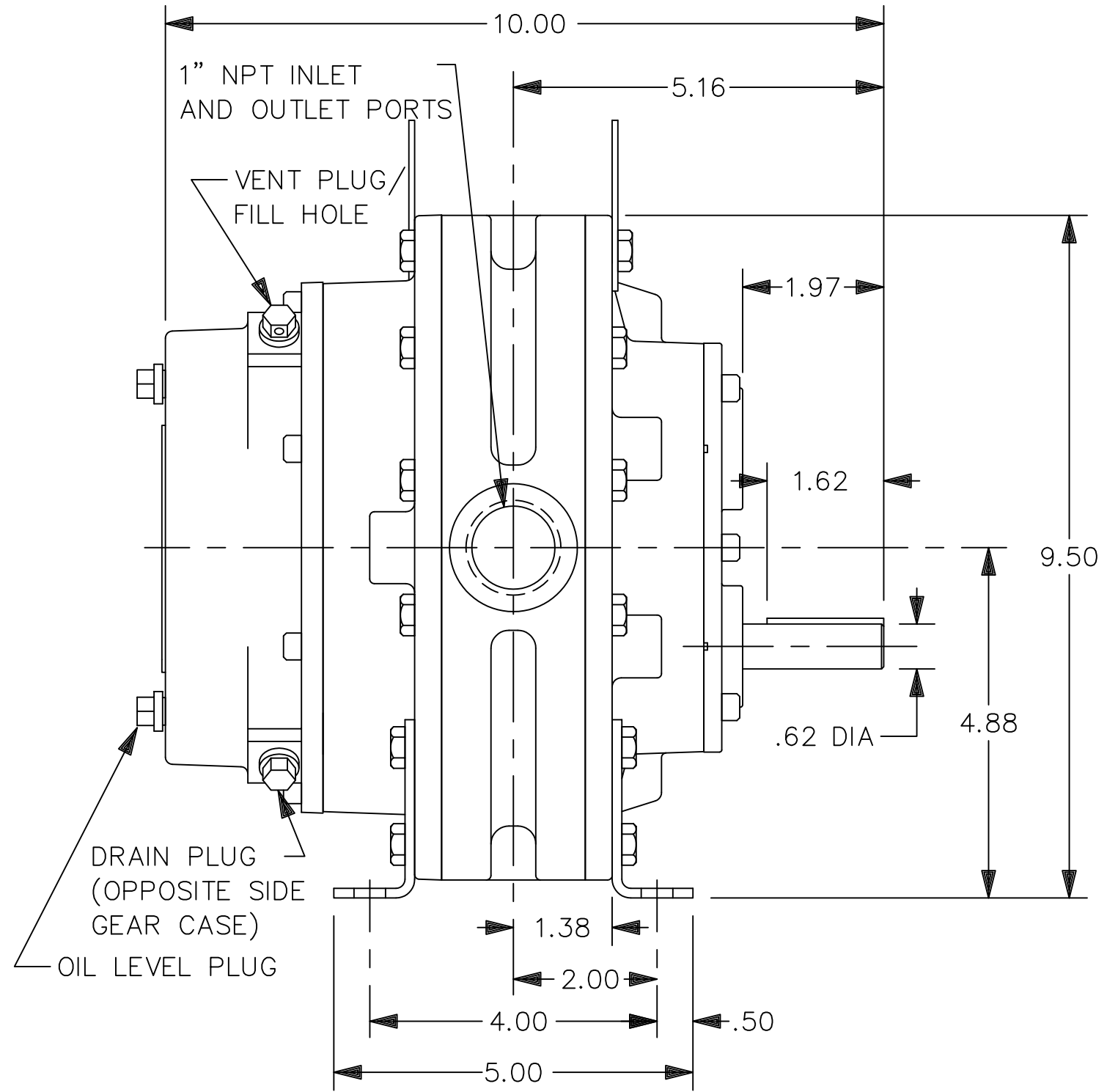

ESTIMATED WEIGHT - 36 LBS

CONFIDENTIAL - THE INFORMATION CONTAINED IN THIS DOCUMENT IS THE PROPERTY OF GARDNER DENVER MACHINERY INC. IT IS NOT FOR PUBLIC DISCLOSURE. POSSESSION OF THE INFORMATION DOES NOT CONVEY ANY RIGHT TO LOAN, SELL OR DISCLOSE THE INFORMATION. UNAUTHORIZED REPRODUCTION OR USE OF THE INFORMATION IS PROHIBITED. THIS DOCUMENT IS TO BE RETURNED TO GARDNER DENVER MACHINERY INC. UPON COMPLETION OF THE PURPOSE FOR WHICH IT IS LOANED OR UPON REQUEST.

LET.	REVISION	DATE	DR.	CK.	LET.	REVISION	DATE	DR.	CK.	LET.	REVISION	DATE	DR.	CK.
-	RELEASED (ECN B9604023)													
A	KEY LENGTH WAS 1.25 (1021288)	7/1/04	SLM	SM										

FINISH OF CHAMFERS & FILLETS TO CONFORM TO ROUGHEST ADJACENT AREA

SURFACE ROUGHNESS MAX. PER ASA SPEC.

Gardner Denver Inc.
Peachtree City, Georgia

TOLERANCES: UNLESS OTHERWISE SPECIFIED
 DECIMAL .XX ± .02 .XXX ± .010
 NON-DECIMAL ± 1/16 ANGLES ± 1°

FOR ALL CURRENT SPECIFICATIONS REFER TO BILL OF MATERIAL

NAME: **OUTLINE-BARE UNIT MODEL 2MV**

DR.	SM	4/8/96	MET. APP.
CK.	VS	4/8/96	ENG. APP.

SCALE: HALF

HEAT TREAT SPEC. -

302GAA800

FILE NO. C CAD/CAM

SHEET 1 OF 1